

# MANUAL PROBEHEAD

# PH 150

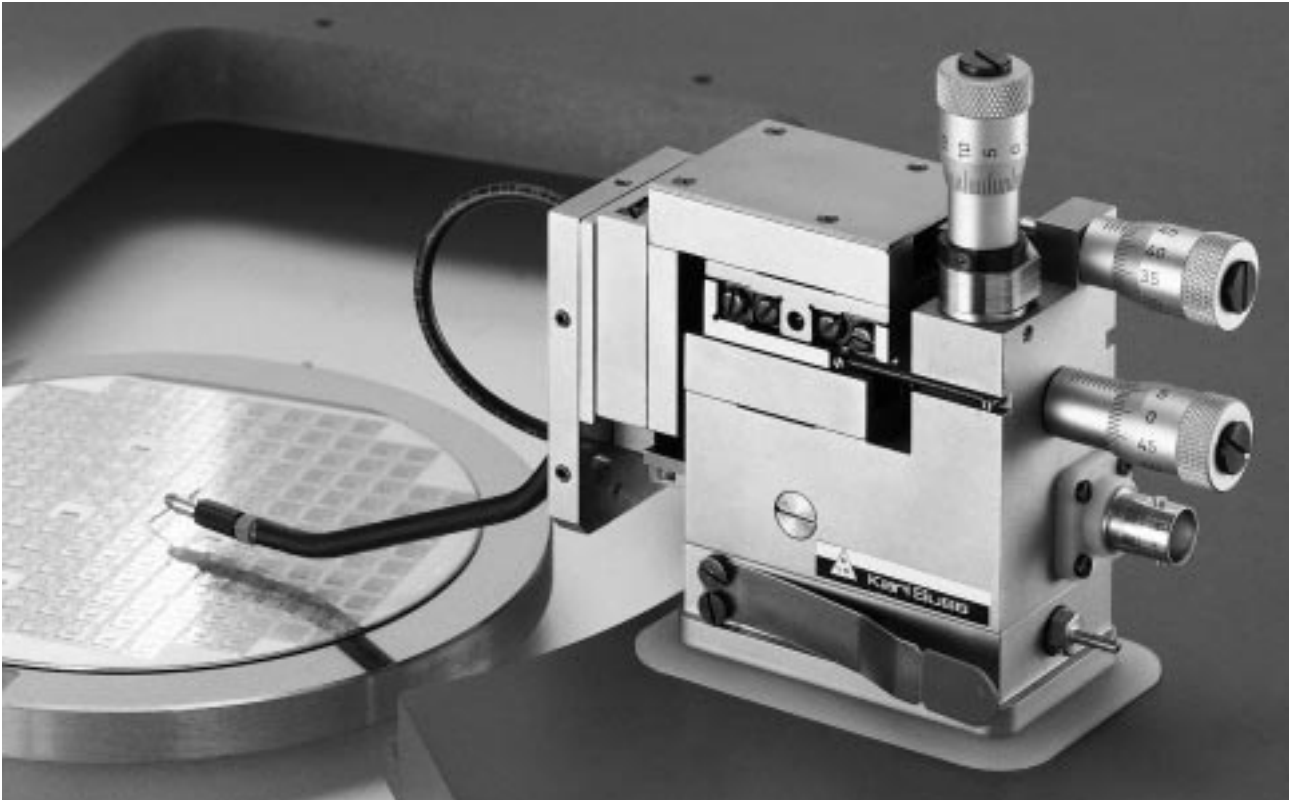

## SUSS PH 150 PROBEHEAD

- ▲ Robust, backlash-free, submicron probing
- ▲ Superior mechanical and ergonomic design
- ▲ True, independent X, Y and Z linear travel
- ▲ Precision cross roller slides and bearings
- ▲ High-resolution positioning screws
- ▲ Strong vacuum base without deviation at release

- ▲ Single and double arms with gold collet clamping
- ▲ Conductive, scratch and corrosion-resistant nickel finish

The SUSS line of manual probeheads offers the advantages of proven high quality, superior mechanical and ergonomic design, and complete product line compatibility.

The SUSS PH 150 has proved to be the most accurate and robust positioner on the market. By using the finest precision components and expert assembly techniques, SUSS

achieves true submicron positioning with zero backlash.

The PH 150 incorporates an independent and uninfluenced XYZ stage system which is free of mechanical cross-talk deviation. Each stage is made of hardened steel and precision cross roller bearings assembled under exact torque measurements.

In addition to superior mechanical design, SUSS always adheres to detail regarding ergonomics and flexibility. Each axis has 10 mm of travel with 50 or 100-tpi (threads per inch), high-resolution screws.



The Z-axis screw is ergonomically located at the rear of the probe head body so as not to transmit finger pressure to the probe needle on touch down. The user has the choice of a Z axis with left or right-handed threads.

The PH150 vacuum base system has superior holding strength. The entire footprint is encompassed by a rectangular rubber lip. Actuation is controlled by a convenient, body-

mounted, "easy touch" lever. This system gives the operator complete control of probehead positioning, without gross probe needle deviation in the Z direction!

The PH150 is compatible throughout the SUSS product line. The PH150 is finished in electroless nickel, which is both scratch and corrosion-resistant. Probe arms are available for all applications, whether standard or special.

### TECHNICAL DATA: SUSS PH150 PROBEHEAD

Travel Range X, Y	10 mm	Feature Resolution	0.5 µm
Travel Range Z	8 mm	Bases	mechanical magnetic vacuum
Z Coarse Adjustment Range	± 7.5 mm	Footprint Dimension	72 x 49 mm
Screw Resolution X,Y,Z	250/500 µm/rev 50/100 tpi		

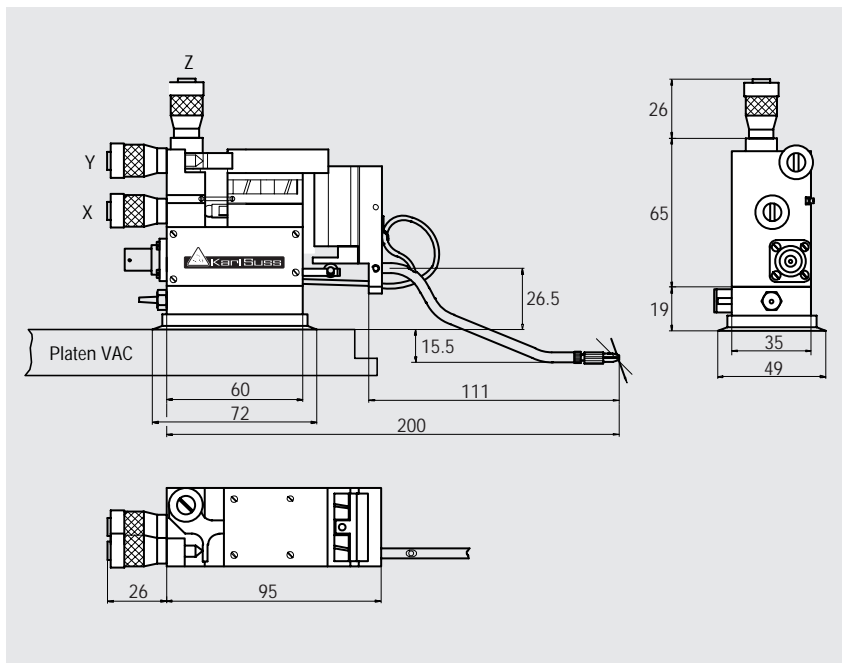

## KARL SUSS WORLDWIDE

### ▲ GERMANY

KARL SÜSS KG · GmbH & Co.  
Schleissheimer Strasse 90  
D-85748 Garching bei München · Germany  
Tel (+49) [0]89/3 20 07-0, Fax -1 62

KARL SÜSS Dresden GmbH  
Süss-Strasse 1  
D-01561 Sacka bei Dresden · Germany  
Tel (+49) [0]3 52 40 -730, Fax -73700

### ▲ FRANCE

KARL SÜSS France SARL  
KARL SÜSS Technique S.A.  
Avenue des Colombières  
F-74490 Saint Jeoire · France  
Tel (+33)-[0]45 03 58-392, Fax -801

### ▲ GREAT BRITAIN

KARL SÜSS Great Britain Ltd.  
23 Ivanhoe Road  
Hogwood Industrial Estate  
Finchampstead · Wokingham · Berkshire  
GB-RG40 4QQ · England  
Tel (+44)-[0]1189-732144, Fax -734395

### ▲ JAPAN

KARL SÜSS Japan K.K. · Yokohama  
カール・ズース・ジャパン株式会社  
〒226 神奈川県横浜市緑区白山1-18-2  
ジャーマン・インダストリー・センター  
Tel (+81)-[0]45-931-5600, Fax -5601

### ▲ ASIA

KARL SÜSS Asia Co., Ltd.  
212/2 Soi Ladprao 10  
Ladprao Road, Ladyao · Jatujak  
Bangkok 10900 · Thailand  
Tel (+66) - 2 938 44 -26, -27  
Fax (+66) - 2 512 5569

### ▲ NORTH AMERICA

KARL SÜSS America Inc.  
P.O. Box 157, Suss Drive  
Waterbury Center · VT 05677 · USA  
Tel (+1) 802-244-5181, Fax -5103

### ▲ INTERNET / WWW

<http://www.suss.com>

Representatives in over 30 countries.  
Please visit the web site for our address list.

